

vitris
Glass fittings with logic

supra

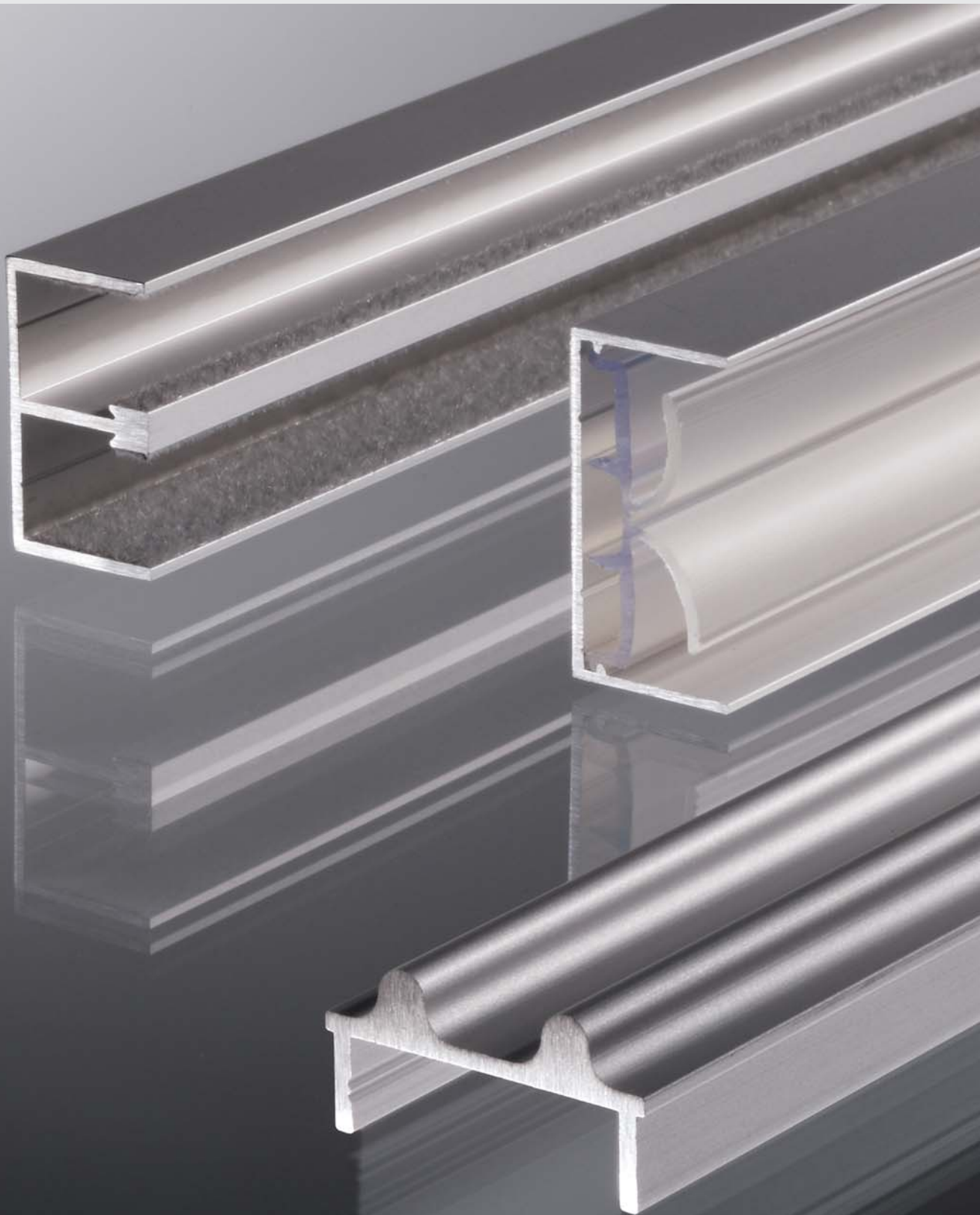

vitris
supra

Supra is a universally usable sliding fittings system for glass thicknesses of 4, 5, 6 and 8 mm. The high quality flocking of the top-twin guides, the superior roller technology, the secure combination of glass and metal through transparent bedding profiles as well as the invisibly integrated damping and anti-theft devices provide for the perfect, long-lasting easy and quiet functioning of the glass sliding doors. Endurance tests undertaken by Willach demonstrate the superior roller technology in comparison to conventional rollers: even after 40,000 sash movements there was no recognisable or noticeable wear.



Supra profiles are available in the finishes silver, gold and stainless steel anodised as well as white powder-coated.

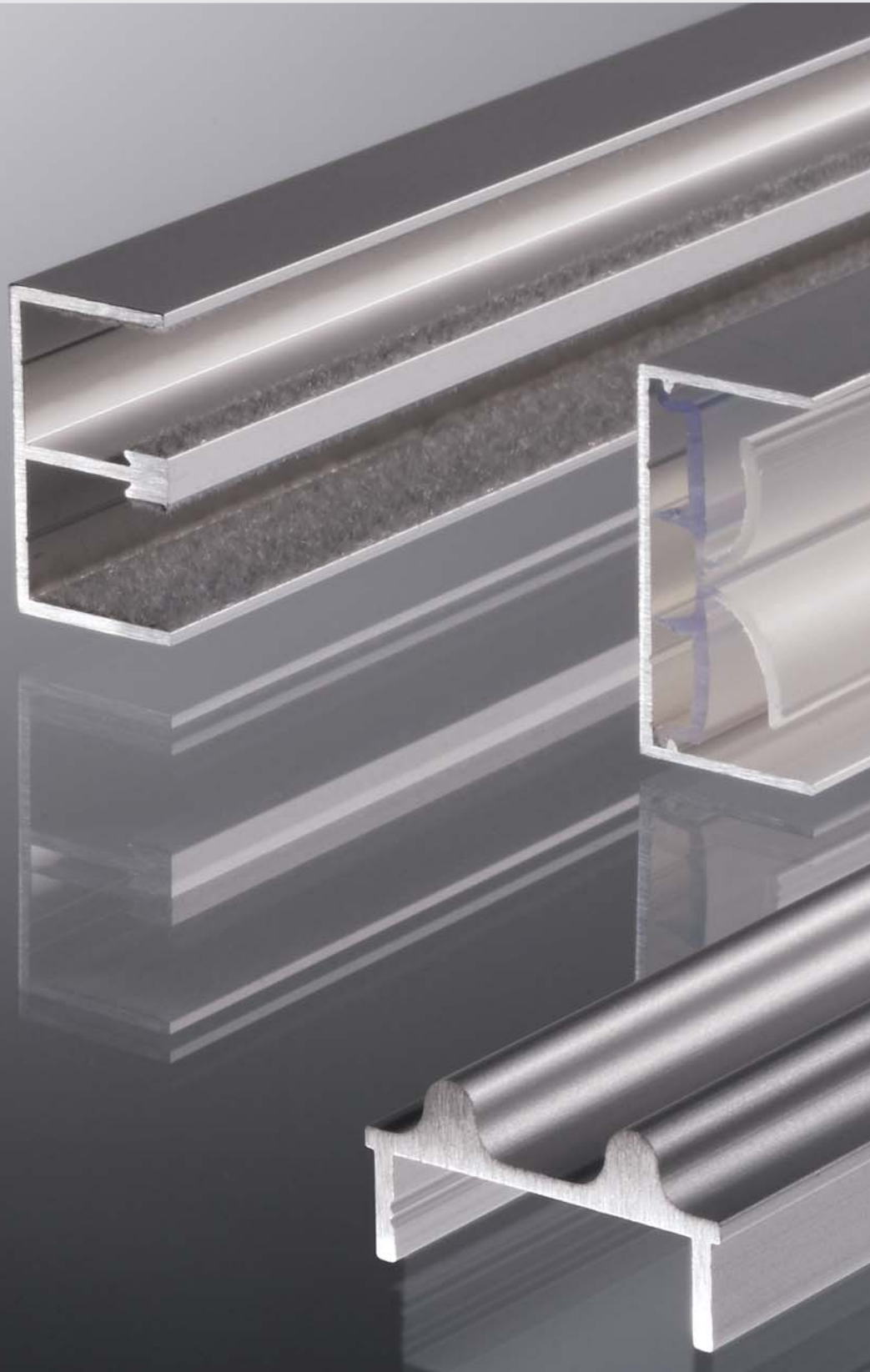

1 Dust protection and damper profile

The Supra frame profile sections enable the flush assembly of the sash and runner section. The dust protection and damper profile forms an optimum buffer zone between glass and metal and ensure that no dust can get in.

2 Supra roller technology permits a load of up to 25 kg with 2 rollers and up to 50 kg with 4 rollers (result of endurance tests at the Willach sliding door test facility).

3 Non-wearing flocking provides for long-lasting quiet running action and prevents "rattling" of glass sliding doors.

4 Supra frames allow for visually convincing solutions. Two additional components enable all-round frame designs.

5 Fast assembly
Double-sided self-adhesive strips on Supra bottom tracks enable fast assembly without unwanted screw holes or screw heads.

6 Single bottom tracks and single top guides allow for single or multiple sash designs.

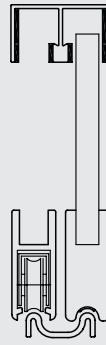

Supra fittings

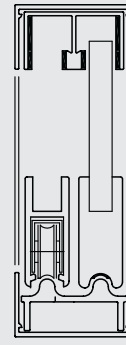

Supra frame fittings

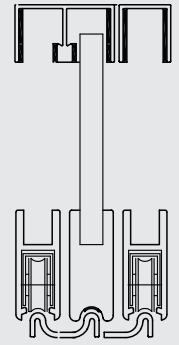

Supra triple track fittings



1 Dust protection and damper profile



2 Supra roller assembly technology



3 Non-wearing flocking



4 Supra frame fittings



5 Fast assembly



6 Single and twin-bottom track



Willach belongs to the leading producers of glass fittings in Europe. The manufacture of products to the highest quality and precision standards has been the supreme dictum of the company since its establishment in 1889. Numerous technical innovations and intelligent solutions with attention to detail meant that Willach was able to build up its pioneering reputation at an early stage. With the Vitris product line, Willach today offers a comprehensive system of high quality glass

door fittings, sliding door locks and slot bar systems for discerning interior, shop and trade show furnishings. Vitris products are certified in accordance with ISO standards and are manufactured at Willach's Ruppichteroth (Germany) production site to meet stringent manufacturing standards. This forms the basis for the excellent quality and consistently high level of ability of the complete Vitris range.

Gebr. Willach GmbH
Stein 2
D-53809 Ruppichteroth
Germany

Tel.: +49 (0)2295 92 08 0
Fax: +49 (0)2295 92 08 429
info@vitris.eu
www.vitris.eu

Certified ISO 9001 by



The Vitris product range

Vitris Penda/Bipenda: Hanging sliding system for glass thicknesses up to 8 mm

Vitris Robustus: Sliding system for glass thicknesses from 8 to 12 mm

Vitris Secura: High security cylinder lock system for the complete range of Vitris sliding systems

Vitris shelving bracket and slot bar system for attractive shelving systems of glass and timber

Vitris Dura/Durus: Gliding system (without roller assembly) for glass sliding doors of 4 – 6 mm glass thickness

Mirror fixing profiles

Glazing profiles: U-profiles, corner profiles, end profiles and central profiles



vitris